

Keyless Entry - Keypad Diagnostics

TSB 06-15-8

08/07/06

KEYPAD DIAGNOSTICS - DEALER INSTALLED ACCESSORY

FORD:

1998-2006 Taurus
1999-2003 Escort
1999-2006 Mustang
2000-2006 Focus
2002-2005 Thunderbird
2005-2006 Five Hundred, Freestyle
2006 Crown Victoria, Fusion
1998-2006 Expedition, Explorer, F-150, Ranger
1999 F-250 Light Duty
1999-2003 Windstar
1999-2006 F-Super Duty
2000-2005 Excursion
2000-2006 E-Series
2001-2003 Explorer Sport
2001-2005 Explorer Sport Trac
2001-2006 Escape
2004 F-150 Heritage
2004-2006 Freestar

LINCOLN:

1998-2006 Town Car
2000-2006 Lincoln LS
2006 Zephyr
1998-2006 Navigator
2002-2003 Blackwood
2003-2005 Aviator
2006 Mark LT

MERCURY:

1998-2005 Sable
1999-2002 Cougar
2005-2006 Montego
2006 Grand Marquis, Milan
1998-2006 Mountaineer
2004-2006 Monterey
2005-2006 Mariner

ISSUE

Some vehicles may experience a concern with the [keyless entry](#) keypad. In order to properly diagnose the concern with the keyless entry keypad, it is important to identify

whether the keypad is a factory installed style (wired) or a Genuine Ford Accessory (GFA) radio frequency (RF) style keypad.

ACTION

Use the following Service Procedure to identify GFA RF keypads and provide diagnostic service tips.

SERVICE PROCEDURE

IDENTIFICATION:

1. Production installed [keyless entry](#) keypads are mounted flush with the surface of the vehicle and are wired directly to the module controlling the vehicle's keyless entry system. This style keypad can be diagnosed using the appropriate Workshop Manual (WSM), Section 501-14.

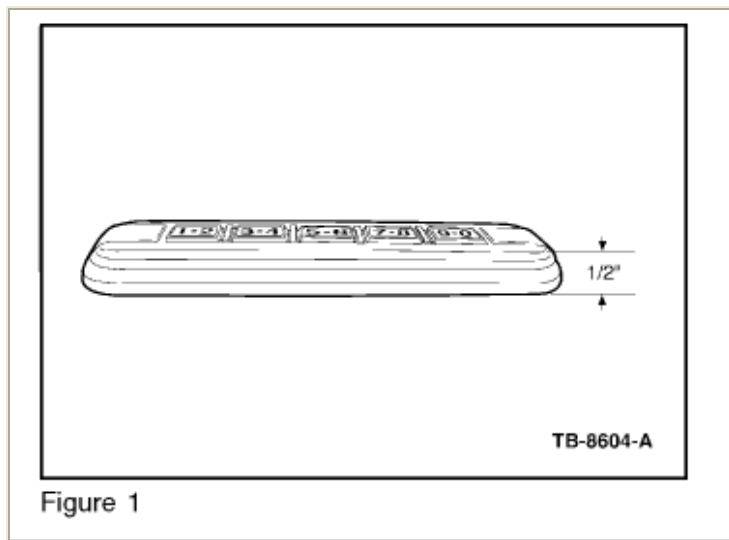

2. Dealer installed GFA RF keypads are adhesive backed and protrude approximately 1/2" (13 mm) from the surface of the vehicle and there are no specific diagnostics available in the WSM (Figure 1).

NOTE THIS RF KEYPAD WAS ALSO USED IN PRODUCTION ON 2004 F-SUPER DUTY VEHICLES BUILT PRIOR TO 12/3/2003. REFER TO WSM, SECTION 501-14 FOR RF KEYPAD DIAGNOSTICS FOR THESE VEHICLES.

GENUINE FORD ACCESSORY KEYPAD DIAGNOSTIC TIPS

1. The keypad operates similarly to a remote keyless entry (RKE) transmitter and is programmed using a similar procedure.

Although the RF keypad is not specifically addressed in the WSM, the RKE transmitter programming portion of the WSM, Section 501-14 can be used as a guide

NOTE THE 7-8 AND 9-0 BUTTONS ON THE KEYPAD MUST BE PRESSED SIMULTANEOUSLY DURING THE PROCEDURE IN ORDER FOR THE KEYPAD TO BE RECOGNIZED AS AN ADDITIONAL REMOTE TRANSMITTER.

Since the GFA RF keypad is essentially another RKE transmitter, the transmitter diagnostic pinpoint tests in the vehicle's WSM can also be referenced even though the buttons serving the lock / unlock functions will differ

2. The GFA RF keypad is serviced as an assembly. The internal battery cannot be replaced separately.
3. If the master code or owner selectable code is lost or forgotten, the GFA RF keypad must be replaced. These codes are not stored in any vehicle module (with the exception of 2004 F-Super Duty vehicles produced prior to 12/3/2003).
4. The GFA RF keypad and all RKE transmitters (the number of transmitters allowable will vary by vehicle) must be reprogrammed together anytime the keypad is replaced, an RKE transmitter is replaced, or the module controlling the keyless entry system on the vehicle (GEM/SJB/VSM/DDM etc.) is replaced.

NOTE THERE IS AN EXCEPTION TO TIP 4 FOR VEHICLES EQUIPPED WITH INTEGRATED KEYHEAD TRANSMITTERS (IKTs) (FUSION/MILAN/ZEPHYR). THE GFA RF KEYPADS FOR VEHICLES WITH IKTs MUST BE PROGRAMMED INDEPENDENTLY FROM THE IKTs. TURN THE IGNITION FROM "OFF" TO "RUN" 8 TIMES WITHIN 10 SECONDS, WITH THE 8TH TIME ENDING IN "RUN". THE DOOR LOCKS WILL CYCLE TO CONFIRM ENTERING PROGRAMMING MODE. PRESS THE 7-8 AND 9-0 BUTTON ON THE KEYPAD SIMULTANEOUSLY TO SEND A LOCK SIGNAL. TURN IGNITION TO OFF. THE LOCKS WILL CYCLE AGAIN TO INDICATE THE END OF THE PROGRAMMING MODE.

5. The keypad will normally illuminate for 5 seconds after one or more buttons are pressed, and the illumination will immediately turn off if the 7-8 and 9-0 buttons are pressed simultaneously (lock all doors). The keypad contains an optical sensor and will not illuminate under bright lighting conditions. The keypad may only illuminate briefly in colder temperatures in order to maximize the battery power available to transmit a lock/unlock signal. The temperature at which this occurs will vary depending upon the keypad battery age and condition. Both of these conditions are a normal function of the Power Save Mode and do not indicate a need to replace the keypad.
6. After entering the keypad code, the system may unlock the driver's door, lock it, then unlock it again, and the keypad will not even briefly illuminate. This is the Alert Mode and is an indication that battery power is very low and the keypad must be replaced.
7. The keypad also contains an Anti-scan feature. If the wrong code has been entered 7 times (35 consecutive button presses) the keypad is disabled for one minute and the keypad lamp will flash during this time.

WARRANTY STATUS: Eligible Under Provisions Of New Vehicle Limited Warranty Coverage

DEALER CODING

BASIC PART NO.
14A626

CONDITION
CODE
42